

2 - Hood

CODE	DESCRIPTION
120313	DOOR MICROSWITCH
150819	CABLE HOLDER PG16 WITH HOLE
160509	FOOT SUPPORT
160803	GASKET D.5
160837	GASKET FOR TIE ROD BC-FC
160838	SLIDING WASHER TIE ROD FC
160905	SLIDING PLATE F. TIE ROD
170812	GREY DOOR HANDLE
180506	DOOR CATCH BR-BC-FC
190619	DOOR CATCH B-F-R
200923	DOOR GASKET
200924	GASKET
210203	RUBBER FOOT 30 MM
260126	SCREW TE 5X12
260223	M5X12 MSH/HD SCREW SPECIAL S/S
260224	TB-SCREW 6X15 B23-10-11-12
260238	M4 X 10 MUSH/HD SCREW
322318	TOP PANEL LF450/F90M
322532	GUIDE
322533	LEFT GUIDE LF450
322975	DOOR LF450/F90M
330209	TIE ROD 5MX305 F-45-55-65
330820	BUSH DOOR SWITCH F2-20-45-5
331764	FIXING PLATE FOR B-F DOOR GASK
341218	HINGE PIN B-F-G
342010	PIN FOR TIE ROD DOOR FC
342212	HOOD LF450/F90M
350725	MICRO BRACKET F300-45-55-65
351582	FRONT PANEL LF450/F90M
381002	PIN F.DOOR MICRO F2-20-45-55
390163	LOWER BACK PANEL
390166	BACK PANEL LF450/F90M
441107	DOOR HINGE BR-BC-FC LEFT
441108	DOOR HINGE BR-BC-FC RIGHT
530228	BASKET

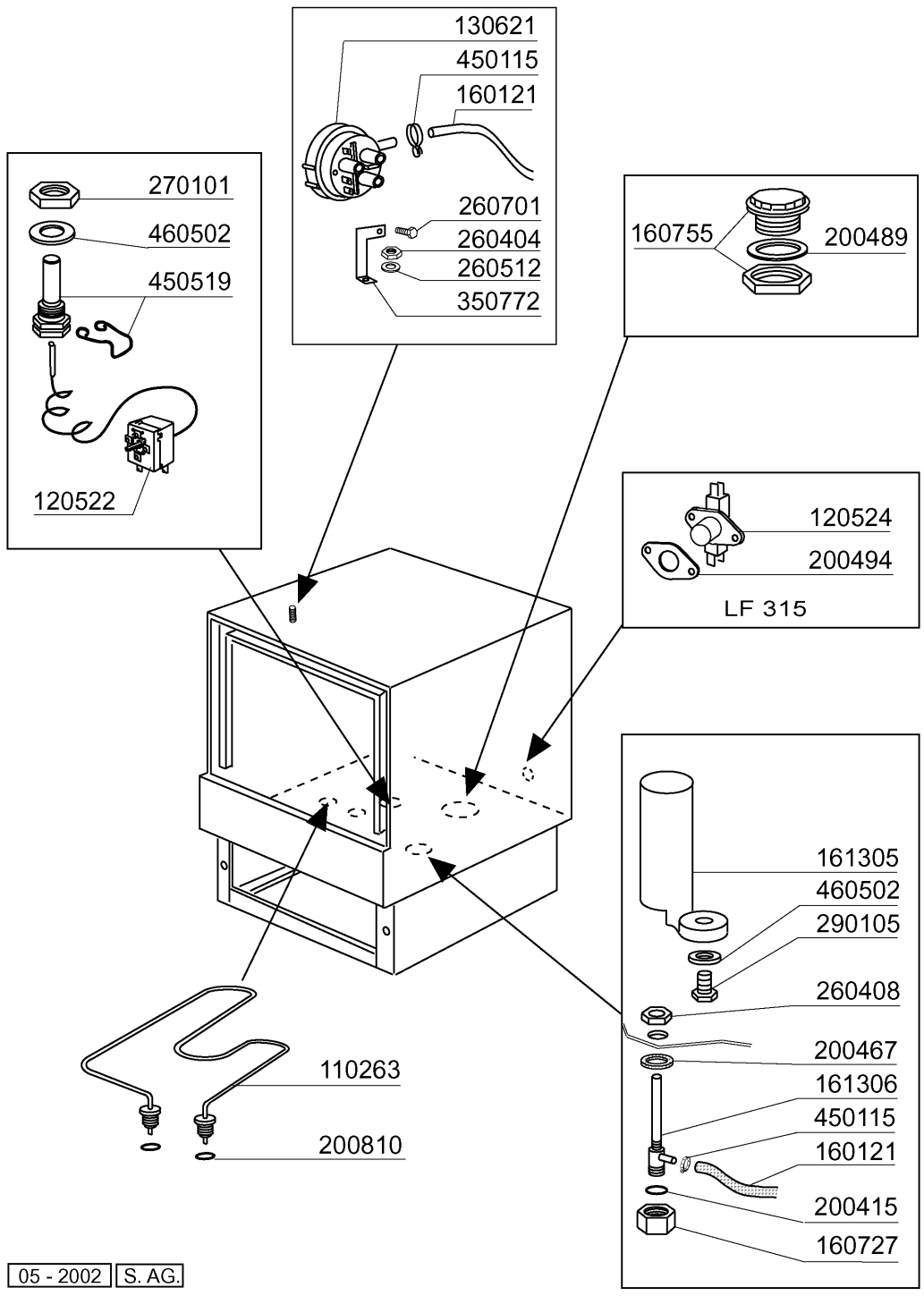

05 - 2002 | S. AG.

3 - Tank

CODE	DESCRIPTION
110263	TANK HEATER 2000W 230V
120522	TANK THERMOSTAT 90Ø
120524	TANKTHERMOSTAT GLASSWASHER
130621	PRESSURE SWITCH FOR BC HR 45/2
160121	HOSE EPDM D. 5 X 9
160727	PLUG 1/2 NTP CAP
160755	PLUG FOR MACHINES WITHOUT SOFT
161305	AIR CHAMBER F45-F80
161306	HOSE FOR AIR CHAMBER F45-80
200415	AIR TRAP GASKET -F2 18,5X10X3
200467	DUTRAL GASKET F. AIR TRAP
200489	GASKET 81X68X3
200494	GASKET FOR TANKTHERMOSTAT BT
200810	O-RING 2,62X9,92X15,6 F.GLASSW
260404	STAINLESS STEEL NUTS D6 UNI 55
260408	S/S NUTS D.12
260512	ST/ST GROWER WASHER D6
260701	SCREW 3,5X9,5
270101	HEXAGON LOCK NUT 1/2"
290105	BRASS-TE-PLUG 1/2"
350772	BRACKET
450115	ELASTIC CLAMP D.8,3/7,8
450519	TANK THERMOSTAT SHIELD C-F
460502	GASKET 30X21X2

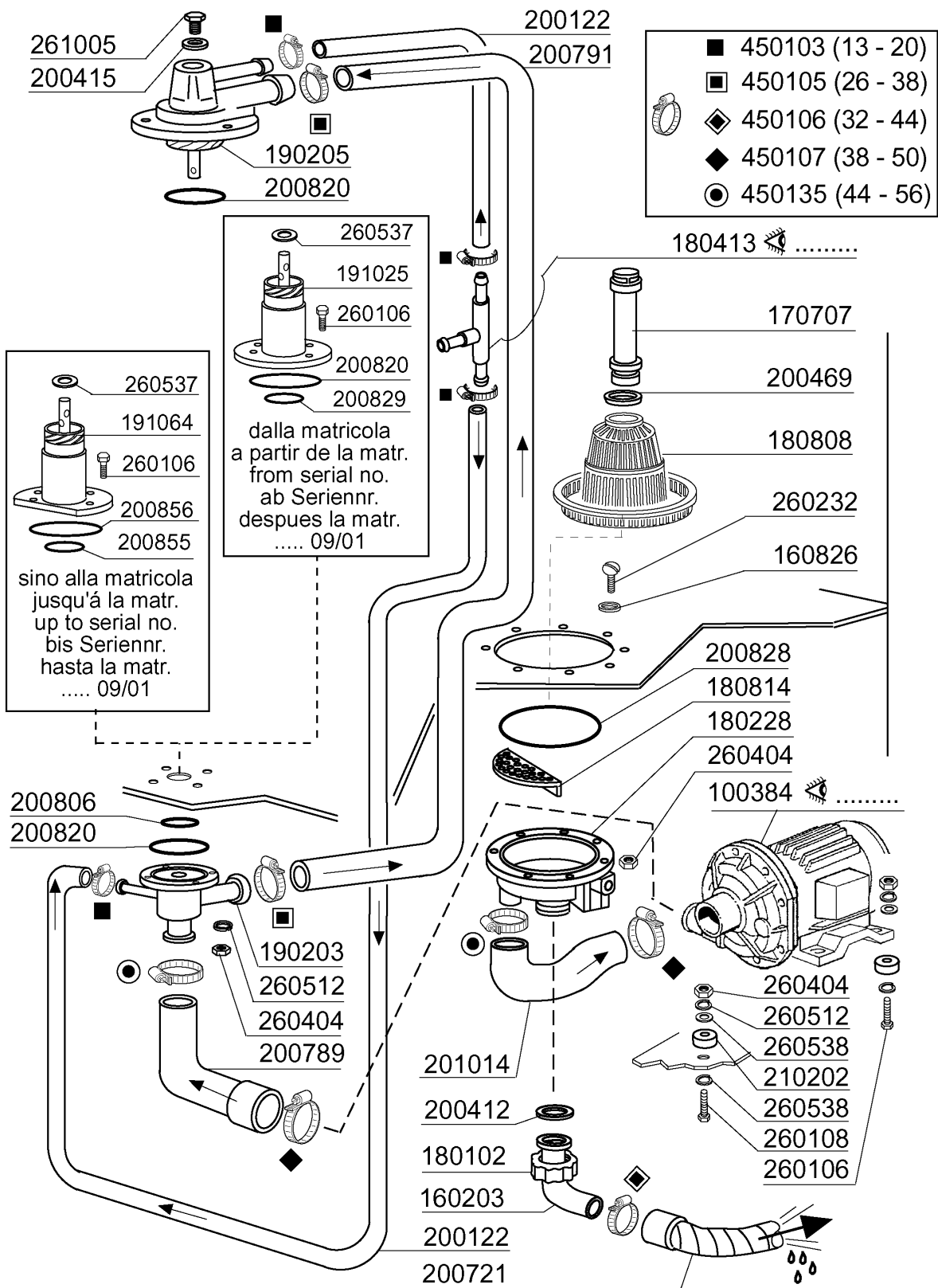

4 - Wash

CODE	DESCRIPTION
100384	PUMP HP 1 240/1-50HZ-1219 1219
160203	ELBOW 1"1/2 N-S-F-C /DRAIN
160826	GASKET 14X6,2X2 B41-F2
170707	OVERFLOW PIPE H140-F2-45-55-R
180102	DRAIN PIPE NUT 1"1/2 F45-55
180228	TANK SUCTION BASIN WITHOU.PRES
180413	TEE NIPPLE D.11,5 - RINSE ASSE
180808	STRAINER F2-45-55-80
180814	PROTECT.FILTER OF INLET PUMPE
190203	LOWER TEE WASH-RINSE F2-45-55-
190205	UPP.TEE WASH/RIN ARM F2-45-55-
191025	LOWER WASH ARM SUPP.B-F
191064	LOWER WASH ARM SUPPORT FOR BC-
200122	HOSE 11X19
200412	GASKET DRAIN 11/2" 45X33X3
200415	AIR TRAP GASKET -F2 18,5X10X3
200469	STAND PIPE O RING 45X35,5X7
200721	DRAIN HOSE 28X35 2MT.
200789	OUTLET HOSE FC
200791	UPPER/LOWER WASH HOSE FC53
200806	O-RING 2,62X13,10X18,34
200820	O-RING151 46,99X5,33X57,6
200828	O-RING 183,75X190,81X3,53
200829	O-RING 81,92X92,58X5,33
200855	GASKET LOWER WASH ARM SUPPORT
200856	O-RING 82,22X87,46X2,62
201014	PUMP INLET HOSE F90M/LF450
210202	RUBBER FOOT GLASSWASHER
260106	SCREW TE 6X25
260108	SCREW TE 6X40
260232	STAINL.ST TB SCREW 6X25 B15-6-
260404	STAINLESS STEEL NUTS D6 UNI 55
260512	ST/ST GROWER WASHER D6
260537	STAINL.STEEL FLAT WASHER D13X2
260538	WASHER 18X6X1,5 ST/ST
261005	SCREW F. TEE UP.WASH F2-B41
450103	CLAMP FE ZN. 13-20 H=9
450105	CLAMP FE ZN. 26-38 H=12,2
450106	CLAMP FE ZN 32-44 H=12,2
450107	CLAMP FE ZN 38-50 H=12,2
450135	CLAMP FE ZN. 44-56 H=12,2

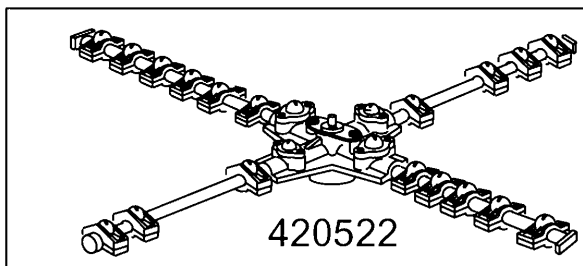
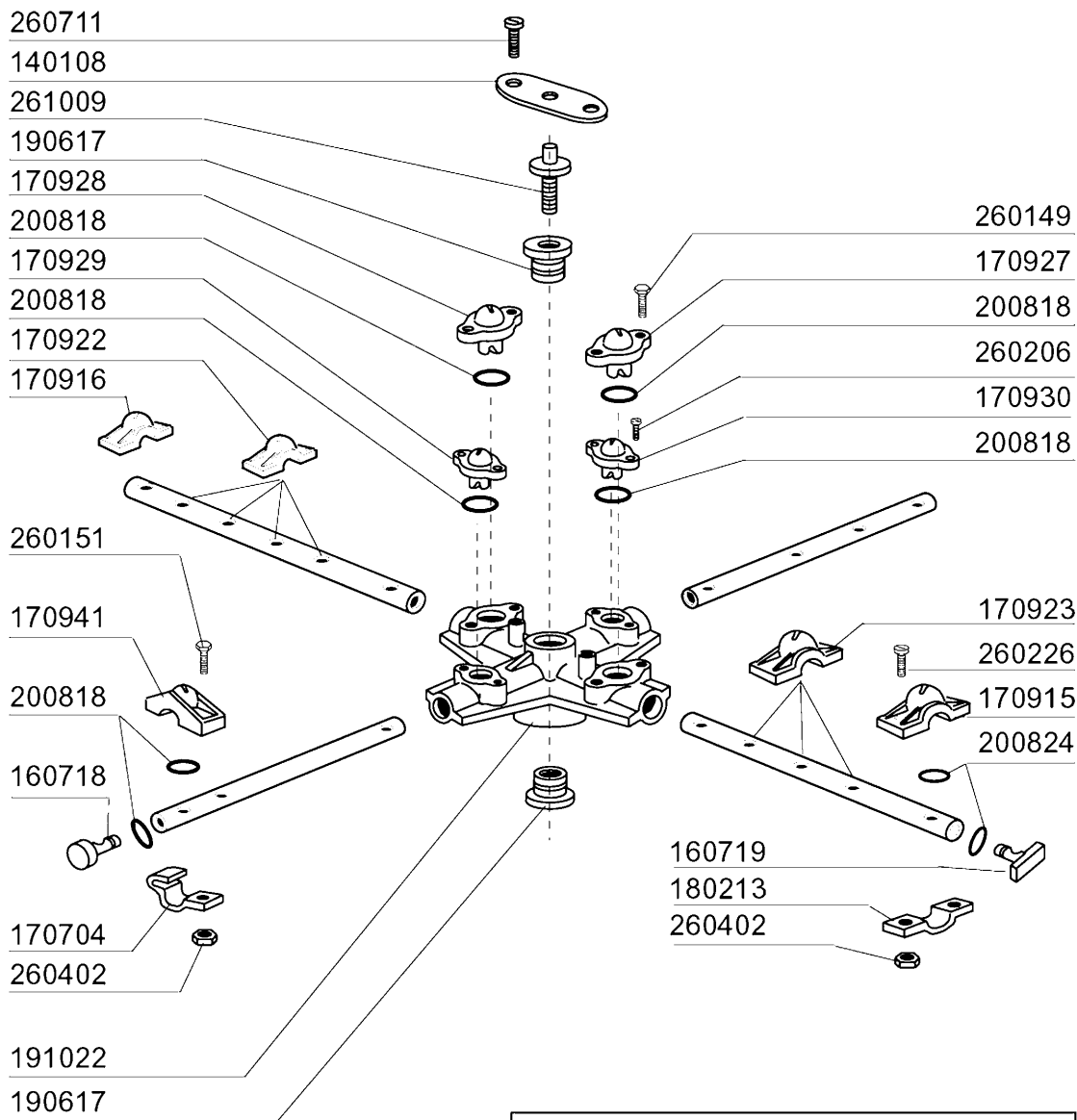

5 - Wash arm

CODE	DESCRIPTION
140108	PLATE FOR WASH ARM
160718	PLUG F. RINSE ARM F2-C34M
160719	PLUG FOR WASH ARM D.18
170704	RINSE NOZZLE BOTTOM F-B-C33
170915	RIGHT JET B-F
170916	LEFT JET B-F
170922	WASH JET LEFT DLX-ULX
170923	WASH JET RIGHT ULX-DLX
170927	WASH JET F2-C-GRAY
170928	IDLE JET F2-C-GRAY
170929	RINSE JET F2-C-GRAY
170930	IDLE JET F2-C-GRAY
170941	RINSE JET USA
180213	FLANGE F.JET LOCKING F2-C34
190617	BUSH
191022	WASH ARM CENTRAL CROSS F-B
200818	O-RING 1,78 X 6,75 X 10,31
200824	O-RING 1,78X12,42X15,98
260149	SCREW TE 4X25
260151	SCREW TE 4X12
260206	SCREW TCP 4X22
260226	STAINL.ST TCP SCREW 4X12 A2 UN
260402	STAINLESS STEEL NUT D4 UNI 55
260711	SCREW 4,2X13 A2 DIN7972
261009	RETAIN.SCREW FOR WASH-RINSE AR
420522	WASH ARM F90M/LF400

6 - Rinse assembly

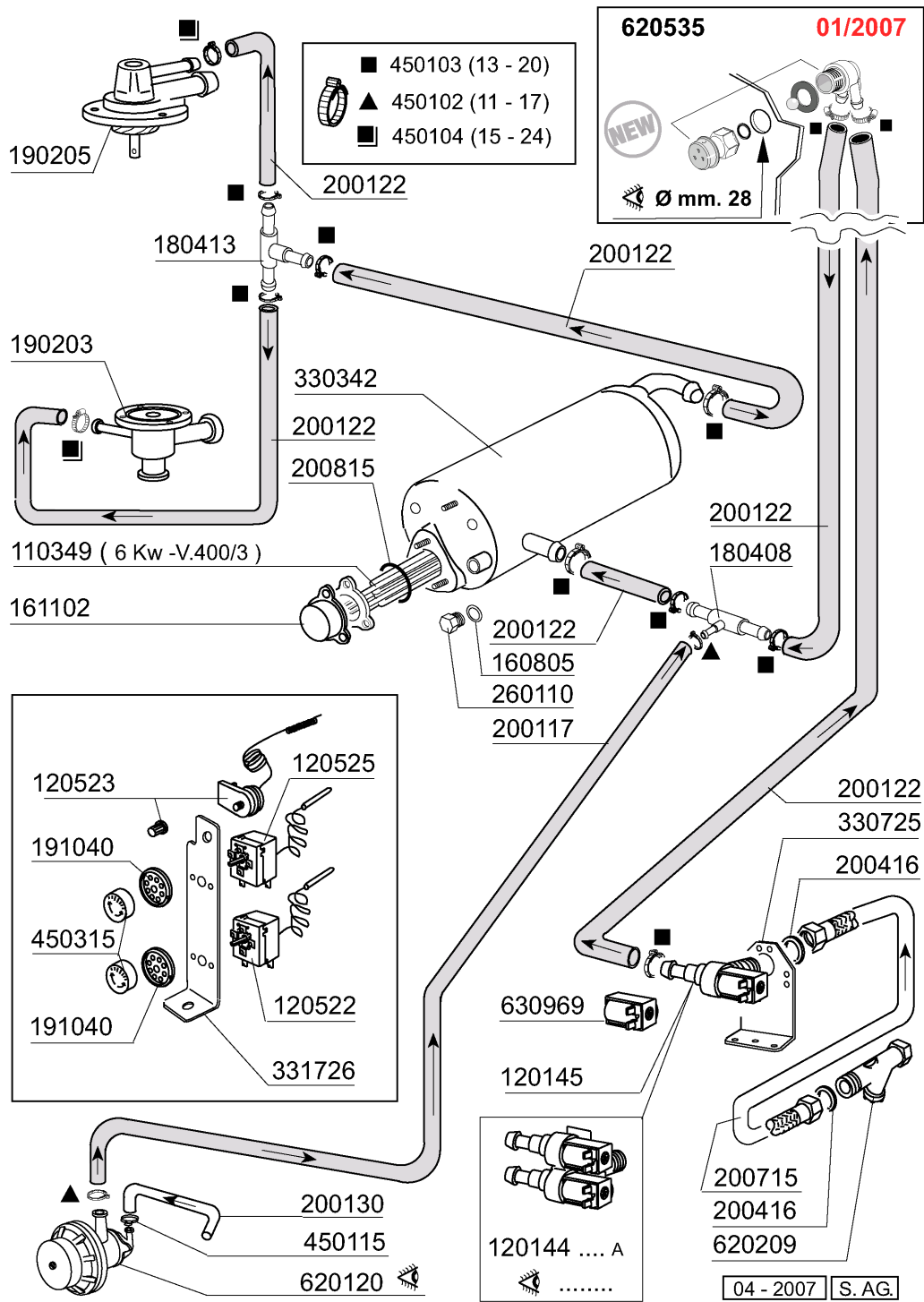

04 - 2007 | S. AG.

6 - Rinse assembly

CODE	DESCRIPTION
110349	HEAT.ELEMENT 6000W 230/400V
120144	SOLENOID VALVE FCA 20 LT TYPE
120145	SOLENOID VALVE 12 LT 1 WAY
120522	TANK THERMOSTAT 90Ø
120523	SAFETY THERMOSTAT 110Ø
120525	BOOSTER THERMOSTAT 2 TEMPERAT.
160805	GASKET D.8
161102	ELEMENT COVER MOPL.
180408	TEE-NIPPLE F.INJECT.W/CENTR.RE
180413	TEE NIPPLE D.11,5 - RINSE ASSE
190203	LOWER TEE WASH-RINSE F2-45-55-
190205	UPP.TEE WASH/RIN ARM F2-45-55-
191040	FRAME F.THERMOSTAT KNOB
200117	RUBBER HOSE 7X16
200122	HOSE 11X19
200130	RINSE AID INJECTOR SUCTION HOS
200416	GASKET D. 3/4"
200715	HOSE WATER INLET 2M STAINL.ST
200815	O-RING F. HEAT.ELEM.
260110	SCREW TE 8X10
330342	BOILER C95-C155-C165
330725	STANDARD BRACKET F.SOLEN.VALV
331726	BRACKET FOR 3 THERMOSTATS
450102	CLAMP FE ZN 11-17 H=9
450103	CLAMP FE ZN. 13-20 H=9
450104	CLAMP FE ZN H=12,5 15-24
450115	ELASTIC CLAMP D.8,3/7,8
450315	KNOB F. THERMOSTAT 90Ø
620120	RINSE AID INJECTOR
620209	INLET WATER FILTER
620535	VACUUM BREAKER
630969	COIL S4216 220/50HZ

7 - Water softener

CODE	DESCRIPTION
120144	SOLENOID VALVE FCA 20 LT TYPE
160117	HOSE 6,3X1,1 WITHE
180130	CONNECTION NUT FOR BY PASS (1/
180408	TEE-NIPPLE F.INJECT.W/CENTR.RE
180411	TEE-NIPPLE FOR BY PASS "BTM"
180413	TEE NIPPLE D.11,5 - RINSE ASSE
190203	LOWER TEE WASH-RINSE F2-45-55-
190205	UPP.TEE WASH/RIN ARM F2-45-55-
200117	RUBBER HOSE 7X16
200122	HOSE 11X19
200130	RINSE AID INJECTOR SUCTION HOS
200416	GASKET D. 3/4"
200454	GASKET F. SALT CONT.
200715	HOSE WATER INLET 2M STAINL.ST
200800	HOSE FOR SALT CONTAINER
200822	PLUG GASKET OF SALT CONTAINER
201002	HOSE
330725	STANDARD BRACKET F.SOLEN.VALV
450102	CLAMP FE ZN 11-17 H=9
450103	CLAMP FE ZN. 13-20 H=9
450104	CLAMP FE ZN H=12,5 15-24
450115	ELASTIC CLAMP D.8,3/7,8
620120	RINSE AID INJECTOR
620209	INLET WATER FILTER
620535	VACUUM BREAKER
630969	COIL S4216 220/50HZ
631302	SALT CONTAINER
640209	WATER SOFTENER (4 COLUMNS)

100384 (220/240 V 50 Hz)

100612 (220 V 60 Hz)

HP 1 - Kw 0,75 (1219)

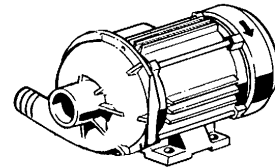

630214

630510

630410

630113

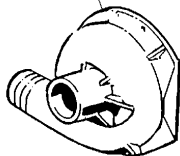

630219

630325

631627 (50 Hz)

631643 (60 Hz)



631207 (12,5 μ F)

04 - 2001 S.A.G.

8 - Pump

CODE	DESCRIPTION
100384	PUMP HP 1 240/1-50HZ-1219 1219
100612	PUMP HP 1 220/1/60HZ F 1219
630113	VOLUTE FIR HP0,5-1,55
630214	FLANGE PUMP HP0,75-1-1,5
630219	FAN HOUSING FIR HP.0,75-1
630325	COOLING FAN F.PUMP 1219/2241
630410	O-RING PUMP FI HP0,5-0,75-1
630510	PUMP SEAL HP0,5-0,75
631207	CONDENSER 12,5MF. 450V 85C
631627	PUMP IMPELLER FI D103 HP 1-1,5
631643	IMPELLER HP1/1,5 60HZD.90-1219

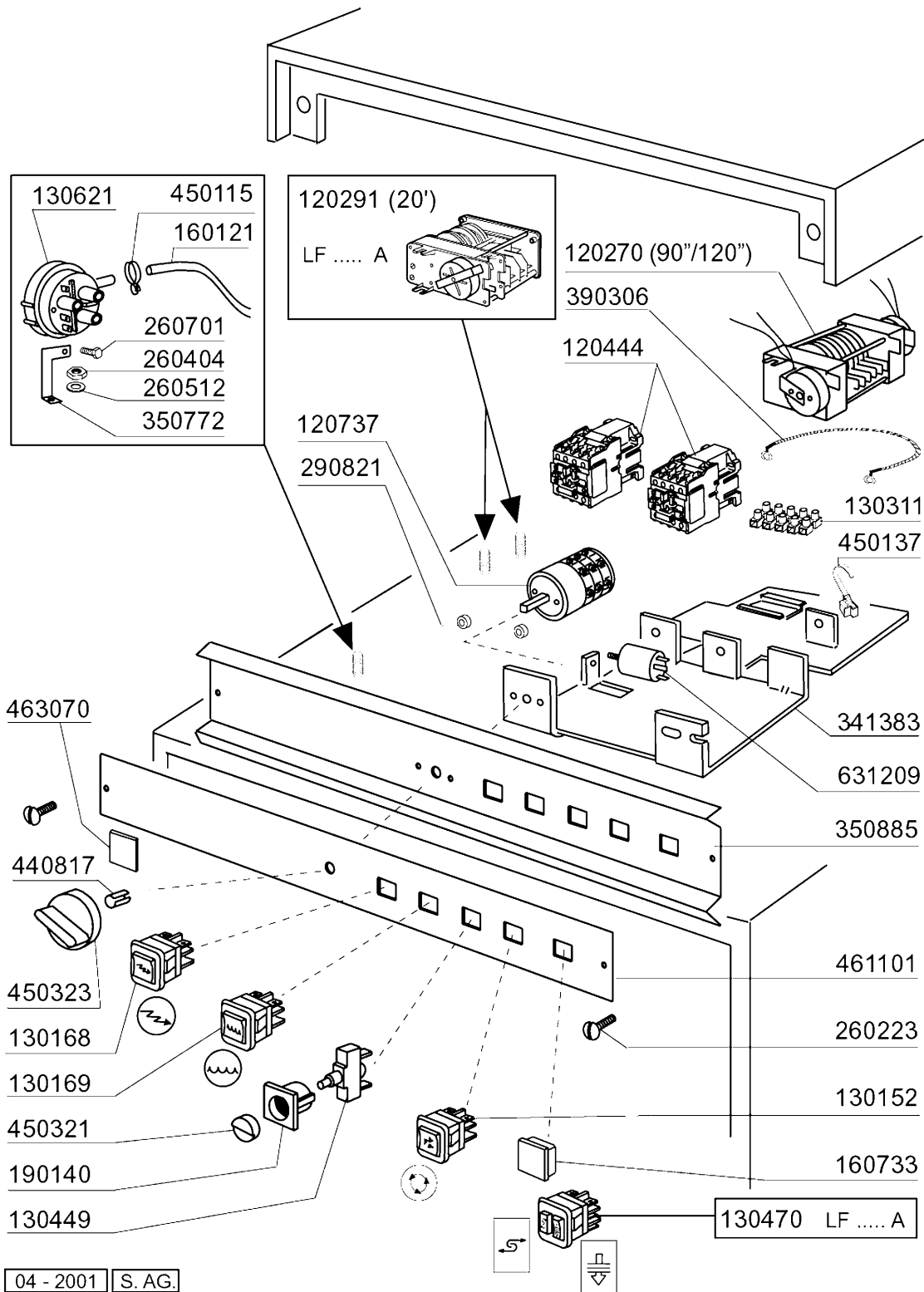

9 - Control-box

CODE	DESCRIPTION
120270	TWIN MOTOR TIMER 75/120"
120291	REGENERATION TIMER 20'
120444	CONTACTOR 9A 220V 50HZ
120737	4 POLE SWITCH 16A 3 POSITIONS
130152	GREEN LIGHT "WORKING MACHINE"
130168	LAMP MACHINE ON - LAV-LINE
130169	LAMP MACHINE READY (LAV-LINE)
130311	TERMINAL BLOCK
130449	PUSH BUTTON BR-BC-FC
130470	PUSH BUTTON+LAMP REGENERATION
130621	PRESSURE SWITCH FOR BC HR 45/2
160121	HOSE EPDM D. 5 X 9
160733	BLANK PLATES
190140	BUTTON HOLDER BR-BC-FC
260223	M5X12 MSH/HD SCREW SPECIAL S/S
260404	STAINLESS STEEL NUTS D6 UNI 55
260512	ST/ST GROWER WASHER D6
260701	SCREW 3,5X9,5
290821	DISTANCE PIECE FOR SWITCH
341383	CONTROL BOX SUPPORT
350772	BRACKET
350885	PANEL SUPPORT "LF"
390306	CABLE
440817	SNAP RING LSCB/1853/17/00
450115	ELASTIC CLAMP D.8,3/7,8
450137	COLLAR CONNECTION WITH BASE 31
450321	GREY COVER FOR PUSH BUTTON BR-
450323	KNOB FOR BC-BR-C95-C155
461101	PLATE LF LAV-LINE
463070	PLATE
631209	ANTI-NOISE FILTER

10 - Rinse aid injector

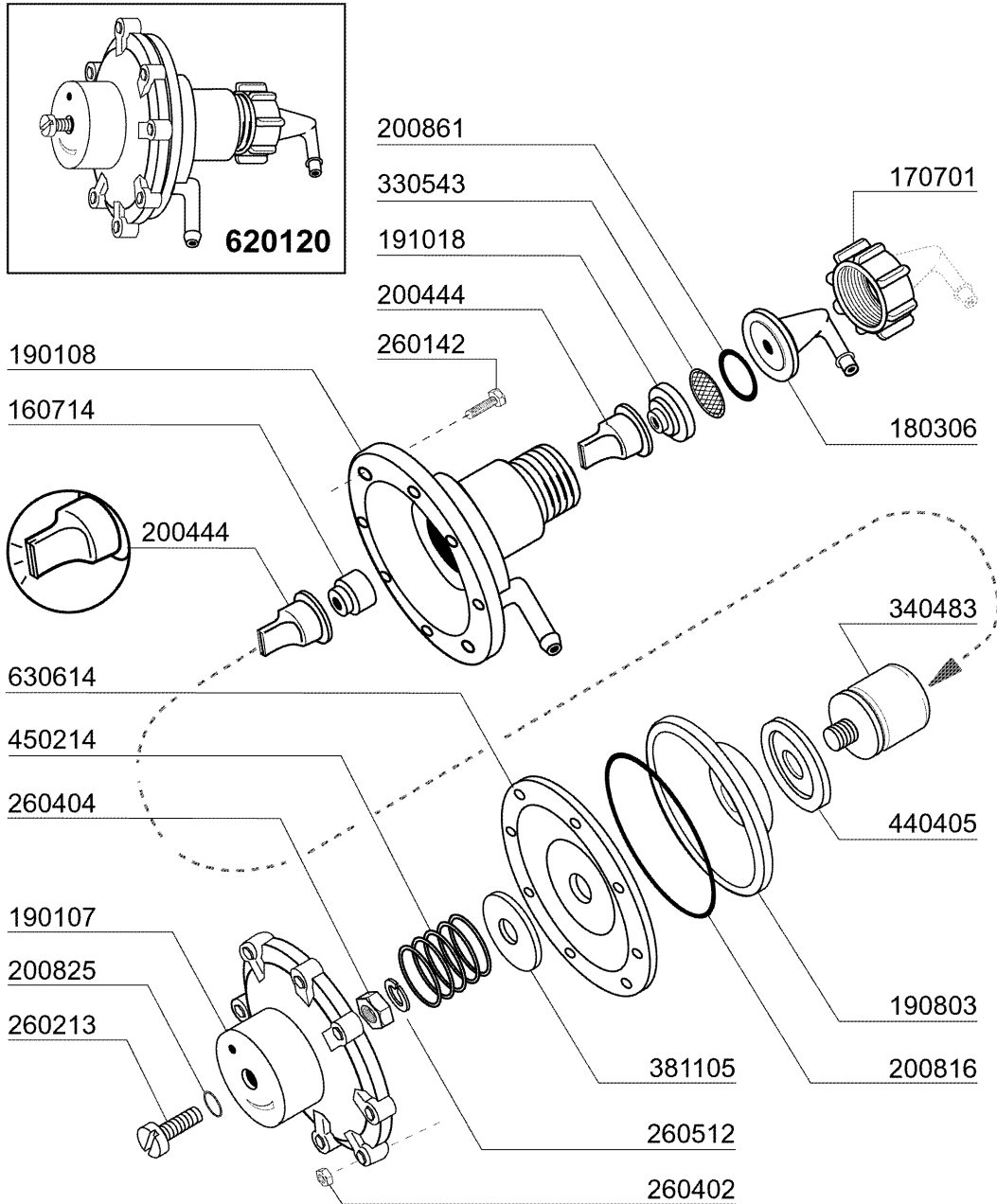

02 - 2004 | S. AG.

10 - Rinse aid injector

CODE	DESCRIPTION
160714	PLUG FOR RINSE AID INJECTOR MO
170701	LOCK NUT 1/2" F.INJECTOR
180306	NIPPLE F.RINSE AID INJECTOR
190107	COVER FOR RINSE AID DISPENSER
190108	VOLUTE FOR RINSE AID DISPENSER
190803	GASKET SUPPORT RING F.INJECT
191018	FILTER SUPPORT RINSE AID INJEC
200444	SUCTION VALVE RINSE INJECTOR
200816	O-RING 2,5X59,2X64,2 RINSE INJ
200825	O-RING 3X5X11 RINSE INJECTOR
200861	O-RING 14X18X2
260142	SCREW TE 4X16
260213	SCREW TCP 5X25
260402	STAINLESS STEEL NUT D4 UNI 55
260404	STAINLESS STEEL NUTS D6 UNI 55
260512	ST/ST GROWER WASHER D6
330543	FILTER RINSE AID INJECTOR D.17
340483	PISTON FOR RINSE AID DISPENSER
381105	DIAPHRAGME DISC
440405	GASKET FOR RINSE AID INJ.
450214	SPRING RINSE AID INJECTOR
620120	RINSE AID INJECTOR
630614	DIAPHRAGM RINSE INJECTOR

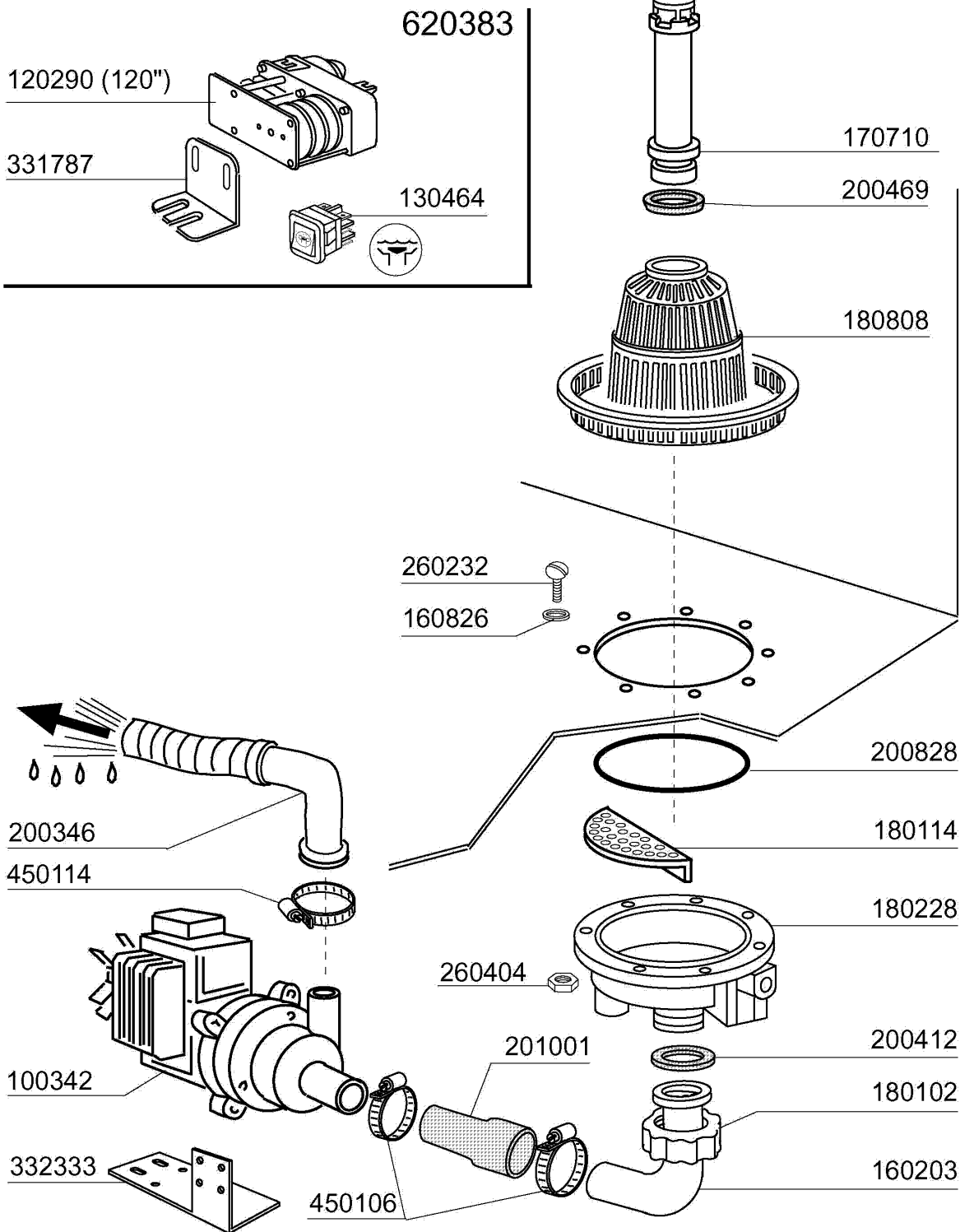

07 - 2001 | S. AG.

11 - Drain pump

CODE	DESCRIPTION
100342	DRAIN PUMP 100 W 220V
120290	TIMER FOR DRAIN PUMP
130464	PUSH BUTTON DRAIN PUMP LAV-LIN
160203	ELBOW 1"1/2 N-S-F-C /DRAIN
160826	GASKET 14X6,2X2 B41-F2
170710	OVERFLOW PIPE X F WITH DRAIN P
180102	DRAIN PIPE NUT 1"1/2 F45-55
180114	KNOB
180228	TANK SUCTION BASIN WITHOU.PRES
180808	STRAINER F2-45-55-80
200346	DRAIN HOSE GLASSWASHER
200412	GASKET DRAIN 11/2" 45X33X3
200469	STAND PIPE O RING 45X35,5X7
200828	O-RING 183,75X190,81X3,53
201001	HOSE FOR DRAIN PUMP LF
260232	STAINL.ST TB SCREW 6X25 B15-6-
260404	STAINLESS STEEL NUTS D6 UNI 55
331787	BRACKET FOR DRAIN TIMER F
332333	BRACKET FOR DRAIN PUMP
450106	CLAMP FE ZN 32-44 H=12,2
450114	CLAMP FE ZN.22-32 H=12,2
620383	DRAIN PUMP KIT LF

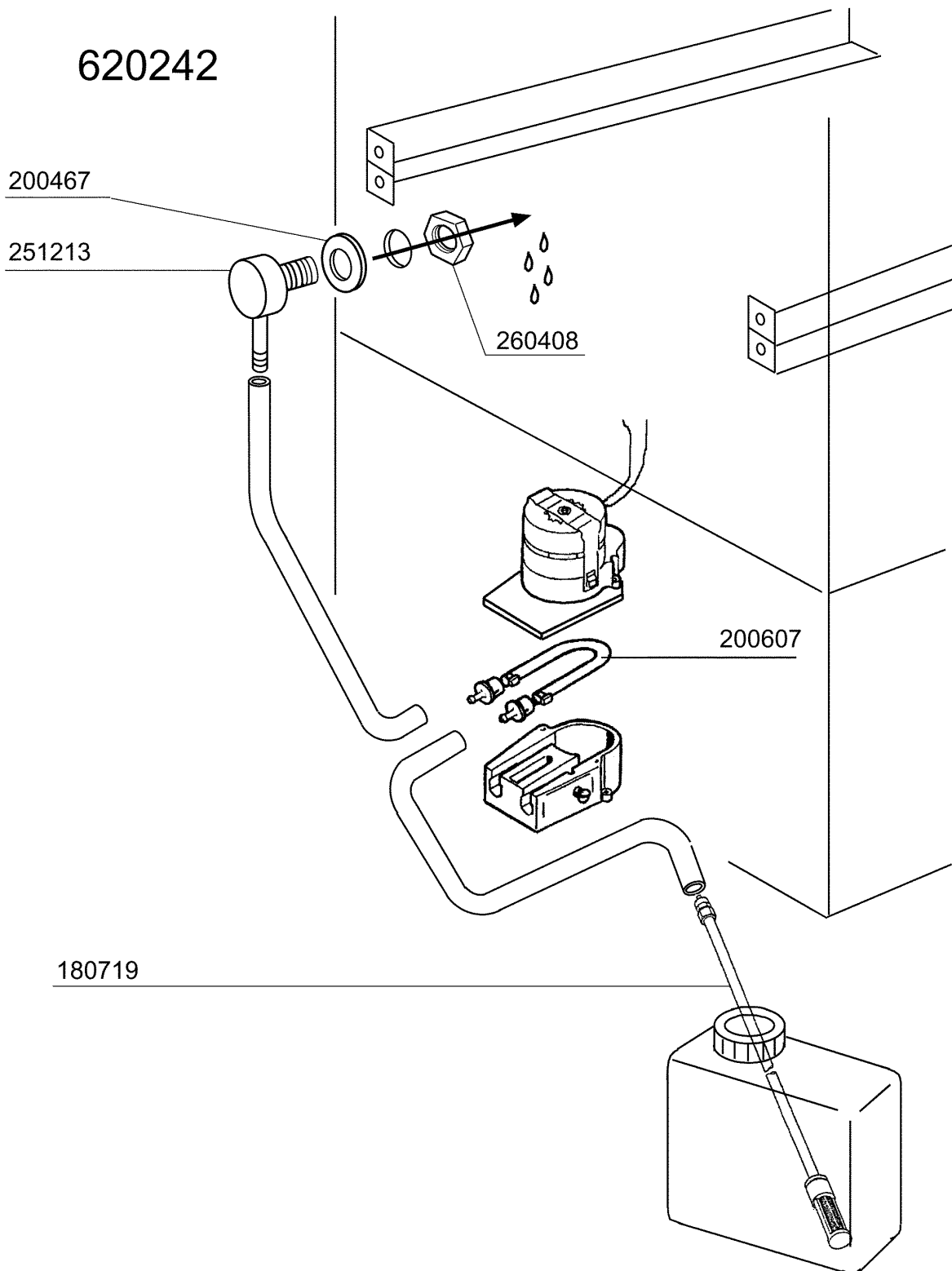

12 - Detergent dispenser

CODE	DESCRIPTION
180719	DETERGENT DISPENSER SUCTION HO
200467	DUTRAL GASKET F. AIR TRAP
200607	DETERGENT DISPENSER HOSE
251213	INJECTIOR S/S FOR DETERGENT IN
260408	S/S NUTS D.12
620242	DETERGENT INJECTOR (KIT)

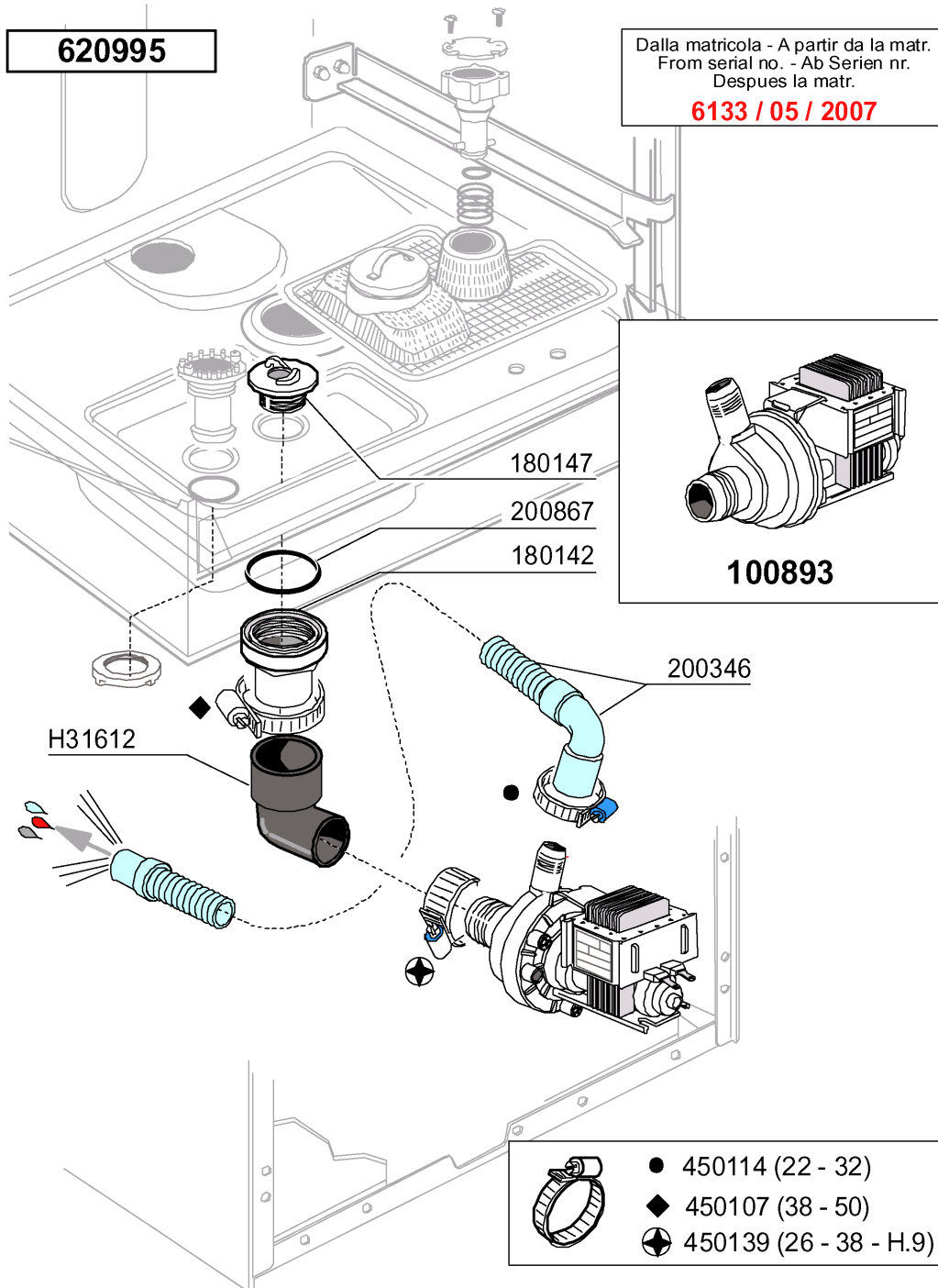

07 - 2007 | S. AG.

13 - Drain pump

CODE	DESCRIPTION
100893	DRAIN PUMP 30W 230/50
180142	CONNECTOR FOR DRAIN PUMP
180147	NUT
200346	DRAIN HOSE GLASSWASHER
200867	GASKET
450107	CLAMP FE ZN 38-50 H=12,2
450114	CLAMP FE ZN.22-32 H=12,2
450139	CLAMP 26-38 H=9
620995	DRAIN PUMP KIT LF MODELS 2007
H31612	HOSE FOR DRAIN PUMP